



**CALIF.
PRE-CUT
HOMES™**

Dennis & Matt Foster
425 El Pintado Rd. Suite 190, Danville, CA 94526-1804
24 Hour Messages (925) 838-2859
24 Hour Fax Line (925) 855-1051
Email: Dfoster@caprecut.com
Mfoster@caprecut.com
www.CAPRECUT.com

CUSTOM 1-CAR GARAGES

CHOOSE THE TYPE OF ROOF LINE YOU WOULD LIKE TO HAVE ON YOUR GARAGE:

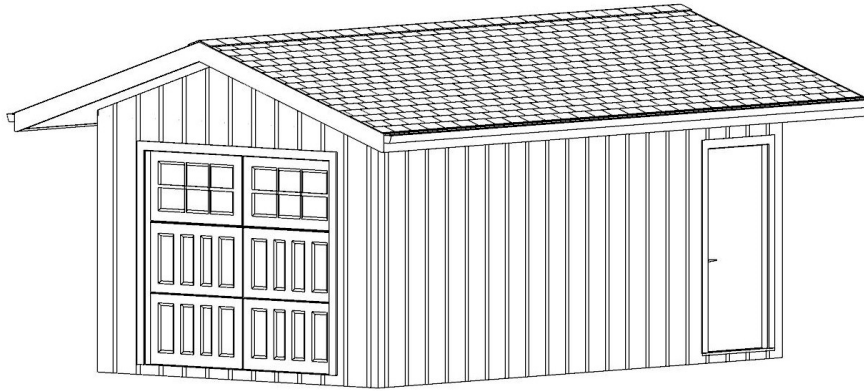

← **ROOF STYLE "A"
GABLE ROOF**

**ROOF STYLE "B"
SHED ROOF →**

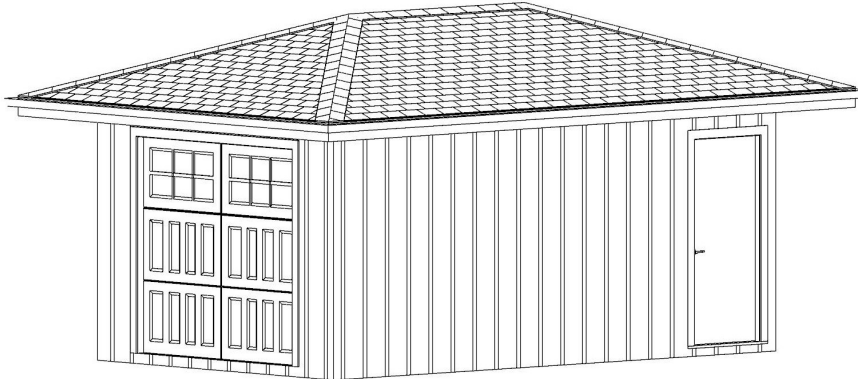
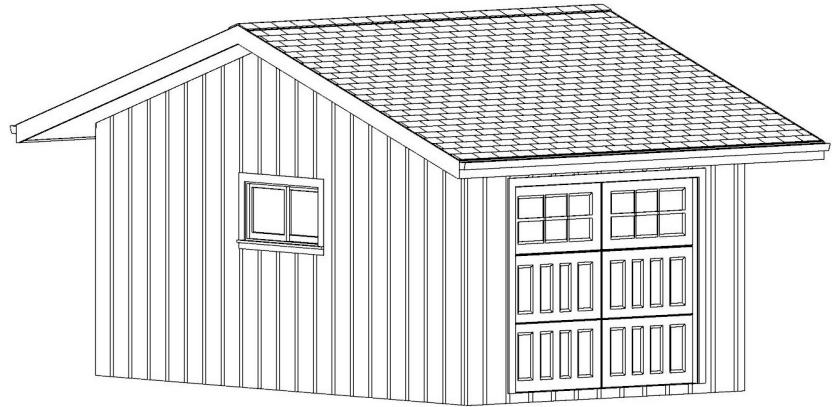

← **ROOF STYLE "H"
HIP ROOF**

**Note: You can change to any kind of siding if you do not want T1-11.
We can supply the Allura carbon fiber cement ship lap siding.
Stucco or any other kind of siding is a local purchase by owner.**



**CALIF.
PRE-CUT
HOMES™**

Dennis & Matt Foster
425 El Pintado Rd. Suite 190, Danville, CA 94526-1804
24 Hour Messages (925) 838-2859
24 Hour Fax Line (925) 855-1051
Email: Dfoster@caprecut.com
Mfoster@caprecut.com
www.CAPRECUT.com

CUSTOM 1-CAR GARAGES

CHOOSE THE SIZE OF GARAGE YOU WOULD LIKE TO HAVE. THESE 1-CAR GARAGE SIZES ARE BETWEEN 12'X20' TO 20'X28'. IF WE DO NOT HAVE THE SIZE YOU WANT, PLEASE LET US KNOW AND WE CAN CREATE ONE FOR YOU.

You can move the man door or window to a different location on the garage.

You can remove or add more windows to the garage. There will be a change in the package cost.

These garages already have an 8'x7' garage door opening. You can go to a larger size if you would like to. Garage door by owner, not in package cost.

The garage door is in the center of the building when you go to the larger sizes. We can move the garage door off to one side if need be. Please keep the door 2' off the corner.

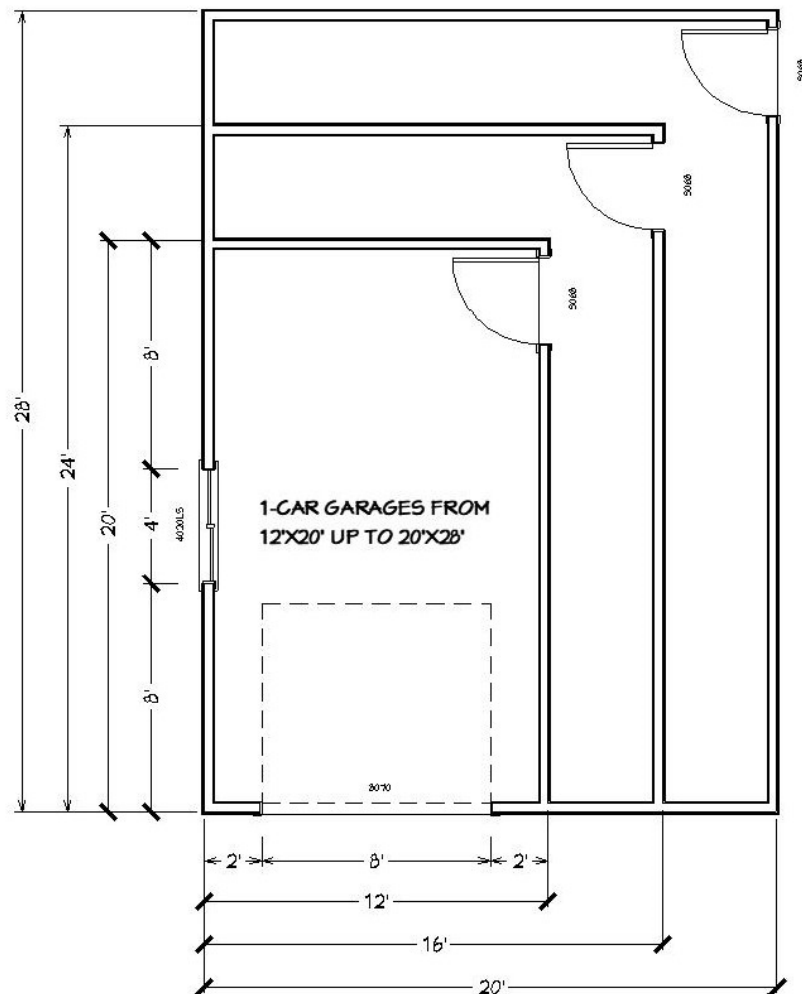

These garages have a truss roof system. We can go to a rafter roof system if you would prefer. There will be a 20% price increase in package cost for a rafter roof system.

IF WE DO NOT HAVE YOUR SIZE, TELL US WHAT YOU WANT!



**CALIF.
PRE-CUT
HOMES™**

Dennis & Matt Foster

425 El Pintado Rd. Suite 190, Danville, CA 94526-1804
 24 Hour Messages (925) 838-2859
 24 Hour Fax Line (925) 855-1051
 Email: Dfoster@caprecut.com
 Mfoster@caprecut.com
www.CAPRECUT.com

CUSTOM 1-CAR GARAGES FROM 12'X20' TO 20'X28'

All garage packages include:

Pre-built 2x4x8' high wall panels with 19/32" LP smart T1-11 OSB shear & siding, 4x12 DF headers, Simpson engineered trusses, 15/32" OSB roof sheathing, 1/2" CCX roof overhang, (1) 3068 Therma-Thu fiberglass man door, (1) 4020 slider Milgard window, Simpson framing hardware, and LP Smart 5/4"x4" & 6" trim.

This price includes an 8.25% CA sale tax & delivery charge of 120 miles from Elk Grove, Ca. If you job site is less than 120 miles from Elk Grove, Ca, your freight fee will be less.

Construction plan fee includes:

A cover page on project, floor plan, foundation plan, (4) elevations, cross section, roof framing plan, engineered from foundation to roof to the CBC building code, foundation & framing building details, truss calcs., site plan, and (4) sets of plans.

If you would like to do your own site plan, we can remove the fee. <\$450>

If you are required to add WUI or 1-hour fire wall protection to the building, add \$200 for each.

A= Gable end roof above garage door.

B= Gable end roof perpendicular to garage door.

H= Hip roof, no gables.

1-CAR GARAGE SIZES	ROOF STYLE "A"	ROOF STYLE "B"	ROOF STYLE "H"	CONSTRUCTION PLAN FEE (*)
240 SQ. FT. 1-CAR 12X20	\$13,600	\$14,986	\$13,460	\$3,350 / \$2,986
288 SQ. FT. 1-CAR 12X24	\$14,722	\$16,519	\$14,607	\$3,350 / \$2,963
336 SQ. FT. 1-CAR 12X28	\$15,845	\$18,052	\$15,754	\$3,350 / \$2,940
320 SQ. FT. 1-CAR 16X20	\$14,406	\$15,255	\$14,170	\$3,350 / \$2,948
384 SQ. FT. 1-CAR 16X24	\$15,686	\$16,946	\$15,478	\$3,350 / \$2,918
448 SQ. FT. 1-CAR 16X28	\$16,967	\$18,637	\$16,787	\$3,350 / \$2,887
400 SQ. FT. 1-CAR 20X20	\$16,220	\$17,031	\$15,909	\$3,350 / \$2,910
480 SQ. FT. 1-CAR 20X24	\$17,658	\$18,588	\$17,379	\$3,350 / \$2,872
560 SQ. FT. 1-CAR 20X28	\$19,061	\$20,437	\$18,848	\$3,350 / \$2,834

IF YOUR JOB SITE IS MORE THAN 120 MILES FROM ELK GROVE, CA. SEE CHART BELOW FOR ADDED FREIGHT FEE

121-200 MI.	201-250 MI.	251-325 MI.	326-400 MI.	401-500 MI.	501-600 MI.	601-650 MI.	OVER 651
\$299	\$494	\$709	\$540	\$1,021	\$1,503	\$1,746	Please call

(*) A PORTION OF THE PLAN FEE IS REBATED BACK TO YOU UPON THE DELIVERY OF YOUR GARAGE PACKAGE UNDER THE CONSTRUCTION PLAN FEE. THE FRIST PRICE IS THE COST FOR CONSTRUCTION PLANS. THE SECOND PRICE WILL BE WHAT YOU SPENT ON PLANS AFTER YOU TAKE DELVIERY OF OUR LUMBER PACKAGE.

NOTE: FOUNDATION, GARAGE DOOR, WIRING, FINISHED ROOFING MATERIAL, FOUNDATION, AND FRAMING LABOR ARE NOT INCLUDED IN OUR PACKAGE COST.

PRICES SUBJECT TO CHANGE. REV 3/21